

## Rocker Pin for Weighbridge Truck Scale

### FEATURES

- For use on steel or concrete weighbridges
- Above ground or pit mounted
- Stainless steel pin
- Plated steel base
- Simple installation
- Low profile

### DESCRIPTION

The 220 Rocker Pin Mount is ideal for use in steel or concrete weighbridge/truckscale applications when used in conjunction with the Model 220 load cell.

It forms a compact assembly which is rugged and tolerant of heavy treatment.

The Rocker Pin Mount assembly allows free motion in any direction in the horizontal plane up to  $\pm 6^\circ$ .



The self-centering design is tolerant of misalignment and can therefore be used in silo weighing applications.

Complicated arrangements that often accompany conventional installation of load cell mountings are avoided.

### OUTLINE DIMENSIONS in millimeters

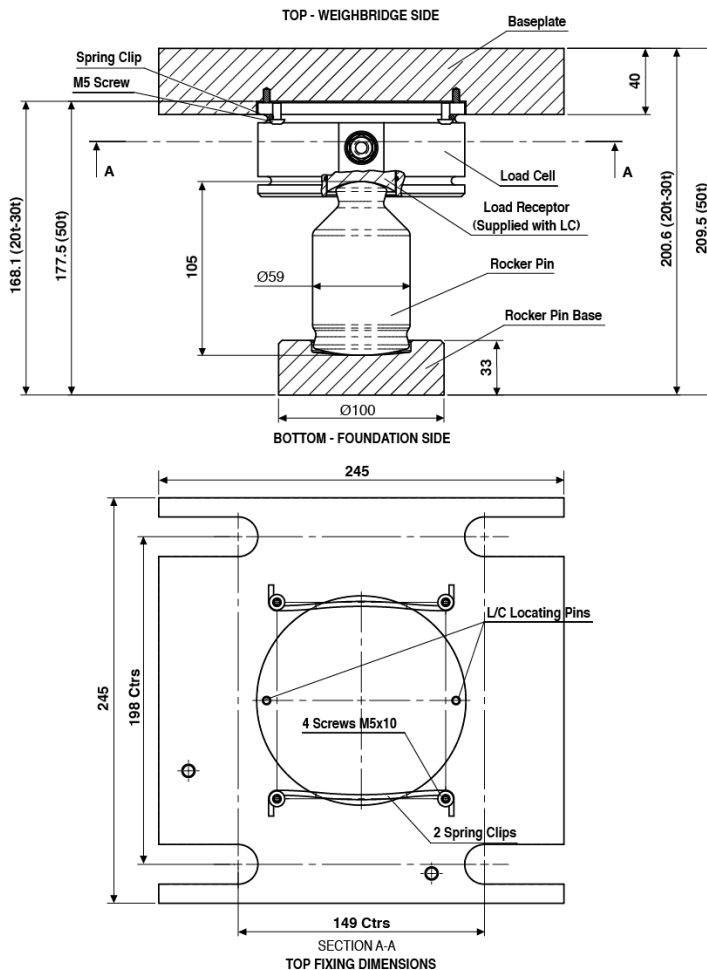

The mounting kit is designated:

MTS-ROCKER-30T

Comprising rocker pin, rocker pin base. Packed weight: 3.5 kg

The baseplate kit is designated:

MTS-BASEKIT-30T

Comprising baseplate, location pins x 2, spring clips x 2, M5 screws x 4. Packed weight: 18 kg

1. To ensure safe use of the rocker pin mount; restraints must be fitted between the weighbridge deck and foundation.
2. Tedea-Huntleigh cannot accept responsibility for the improper installation of the rocker pin mount.
3. Because of the weight of the base plate and consequent freight costs, customers might wish to machine it locally. Manufacturing details of this simple plate are available free of charge on request.
4. A separate kit of spring clips, location pins, and screws is available (MTS-CLIPKIT-30T). Tedea-Huntleigh provide installation details separately, please refer to Technical Support Document.